

LM5026 Evaluation Board

National Semiconductor
Application Note 1387
Robert Bell
September 2005



Introduction

The LM5026 evaluation board is designed to provide the design engineer with a fully functional power converter based on the Active Clamp Forward topology to evaluate the LM5026 controller. The evaluation board is provided in an industry standard half-brick footprint.

The performance of the evaluation board is as follows:

- Input range: 36V to 78V
- Output voltage: 3.3V
- Output current: 0 to 30A
- Measured efficiency: 90% at 30A, 92.5% at 15A
- Frequency of operation: 230kHz
- Board size: 2.3 x 2.4 x 0.5 inches
- Load Regulation: 1%
- Line Regulation: 0.1%
- Line UVLO, Hiccup Current Limit

The printed circuit board consists of 4 layers of 3 ounce copper on FR4 material with a total thickness of 0.050 inches. Soldermask has been omitted from some areas to facilitate cooling. The unit is designed for continuous operation at rated load at $< 40^{\circ}\text{C}$ and a minimum airflow of 200 CFM.

Theory of Operation

Power converters based on the Forward topology offer high efficiency and good power handling capability in applications up to several hundred Watts. The operation of the transformer in a forward topology does not inherently self-reset each power switching cycle, a mechanism to reset the transformer is required. The active clamp reset mechanism is presently finding extensive use in medium level power converters in the 50 to 200W range.

The Forward converter is derived from the Buck topology family, employing a single modulating power switch. The main difference between the topologies are, the Forward topology employs a transformer to provide input / output ground isolation and a step down or step up function.

Each cycle, the main primary switch turns on and applies the input voltage across the primary winding, which has 12 turns. The transformer secondary has 2 turns, leading to a 6:1 step-down of the input voltage. For an output voltage of 3.3V the required duty cycle (D) of the main switch must vary from approximately 65% (low line) to 25% (high line). The clamp capacitor along with the reset switch reverse biases the transformer primary each cycle when the main switch turns off. This reverse voltage resets the transformer. The clamp capacitor voltage is $V_{in} / (1-D)$.

The secondary rectification employs self-driven synchronous rectification to maintain high efficiency and ease of drive.

Feedback from the output is processed by an amplifier and reference, generating an error voltage, which is coupled back to the primary side control through an optocoupler. The COMP input to the LM5026 greatly increases the achievable loop bandwidth. The capacitance effect (and associated pole) of the optocoupler is greatly reduced by holding the voltage across the optocoupler constant. The LM5026 current mode controller pulse width modulates the error signal with a ramp signal derived from the transformer primary. A standard "type II" (pole-zero-pole) is used as a compensation network. The LM5026 provides a controlled delay necessary for the reset switch.

The evaluation board can be synchronized to an external clock with a recommended frequency range of 230 to 300kHz.

Theory of Operation (Continued)

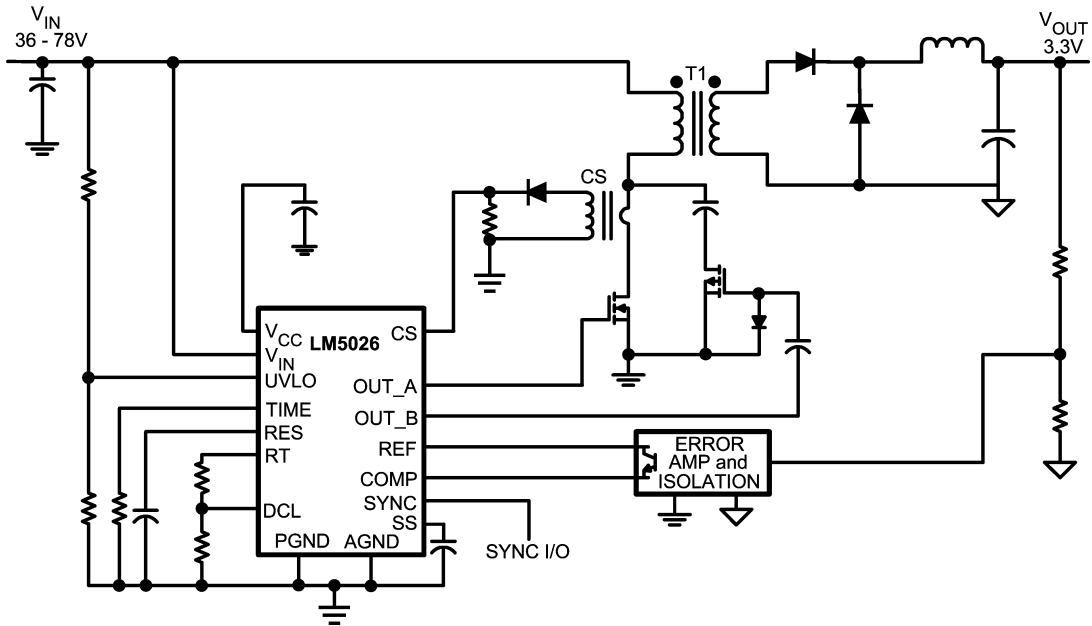

Schematic

20154601

Powering and Loading Considerations

When applying power to the LM5026 evaluation board certain precautions need to be followed. A mis-connection can damage the assembly.

Proper Connections

When operated at low input voltages the evaluation board can draw up to 3.5A of current at full load. The maximum rated output current is 30A. Be sure to choose the correct connector and wire size when attaching the source supply and the load. Monitor the current into and out of the evaluation board. Monitor the voltage directly at the output terminals of the evaluation board. The voltage drop across the load connecting wires will give inaccurate measurements, this is especially true for accurate efficiency measurements.

Source Power

The evaluation board can be viewed as a constant power load. At low input line voltage (36V) the input current can reach 3.5A, while at high input line voltage (78V) the input current will be approximately 1.5A. Therefore to fully test the LM5026 evaluation board a DC power supply capable of at least 80V and 4A is required. The power supply must have adjustments for both voltage and current.

The power supply and cabling must present a low impedance to the evaluation board. Insufficient cabling or a high impedance power supply will droop during power supply application with the evaluation board inrush current. If large enough, this droop will cause a chattering condition upon power up. This chattering condition is an interaction with the

evaluation board undervoltage lockout, the cabling impedance and the inrush current.

Loading

An appropriate electronic load, with specified operation down to 3.0V minimum, is desirable. The resistance of a maximum load is 0.11Ω. The high output current requires thick cables! If resistor banks are used there are certain precautions to be taken. The wattage and current ratings must be adequate for a 30A, 100W supply. Monitor both current and voltage at all times. Ensure there is sufficient cooling provided for the load.

Air Flow

Full power loading should never be attempted without providing the specified 200 CFM of air flow over the evaluation board. A stand-alone fan should be provided.

Powering Up

Using the shutdown pin provided will allow powering up the source supply with the current level set low. It is suggested that the load be kept low during the first power up. Set the current limit of the source supply to provide about 1.5 times the wattage of the load. As you remove the connection from the shutdown pin to ground, immediately check for 3.3 volts at the output.

A most common occurrence, that will prove unnerving, is when the current limit set on the source supply is insufficient for the load. The result is similar to having the high source impedance referred to earlier. The interaction of the source

Powering Up (Continued)

supply folding back and the evaluation board going into undervoltage shutdown will start an oscillation, or chatter, that may have undesirable consequences.

A quick efficiency check is the best way to confirm that everything is operating properly. If something is amiss you can be reasonably sure that it will affect the efficiency adversely. Few parameters can be incorrect in a switching power supply without creating losses and potentially damaging heat.

Over Current Protection

The evaluation board is configured with hiccup over-current protection. In the event of an output overload (approximately 33A) the unit will discharge the softstart capacitor, which disables the power stage. After a delay the softstart is released. The shutdown, delay and slow recharge time of the softstart capacitor protects the unit, especially during short circuit event where the stress is highest.

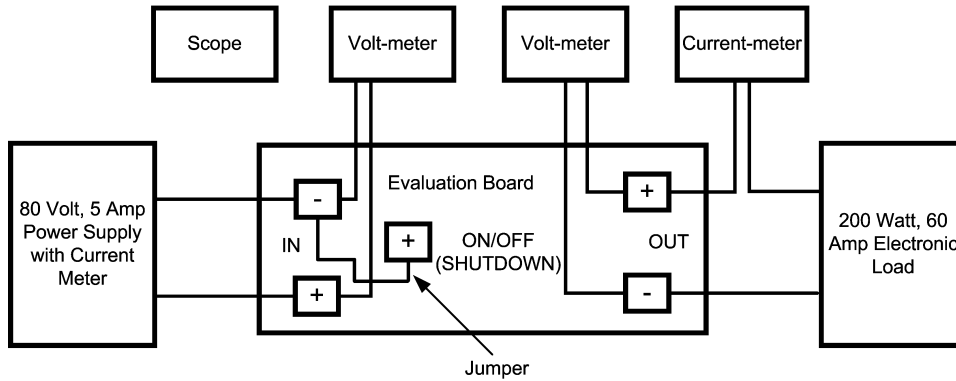

Typical Evaluation Setup

20154602

Performance Characteristics

TURN-ON WAVEFORMS

When applying power to the LM5026 evaluation board a certain sequence of events occurs. Soft-start capacitor values and other components allow for a minimal output voltage for a short time until the feedback loop can stabilize without overshoot. *Figure 1* shows the output voltage during a typical start-up with a 48V input and a load of 5A. There is no overshoot during startup.

OUTPUT RIPPLE WAVEFORMS

Figure 2 shows the transient response for a load of change from 5A to 25A. The upper trace shows minimal output voltage droop and overshoot during the sudden change in output current shown by the lower trace.

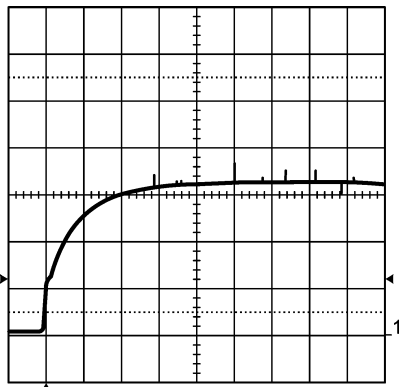

20154604

Conditions: Input Voltage = 48VDC Output Current = 5A
Trace 1: Output Voltage Volts/div = 1V
Horizontal Resolution = 1msec/div

FIGURE 1.

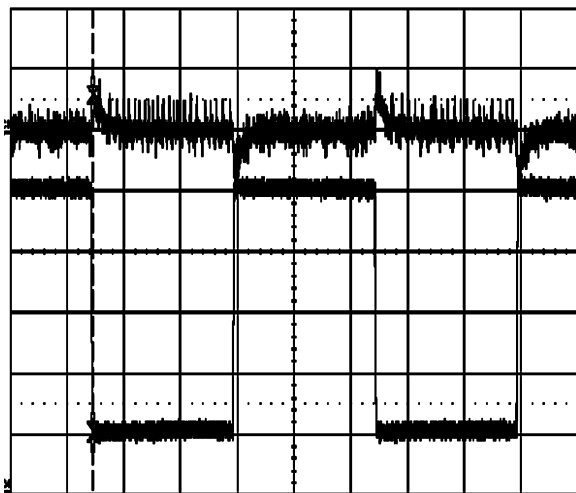

20154615

Conditions: Input Voltage = 48VDC Output Current = 5A to 25A
Trace 1: Output Voltage Volts/div = 0.5V
Trace 2: Output Current, Amps/div = 5A
Horizontal Resolution = 1msec/div

FIGURE 2.

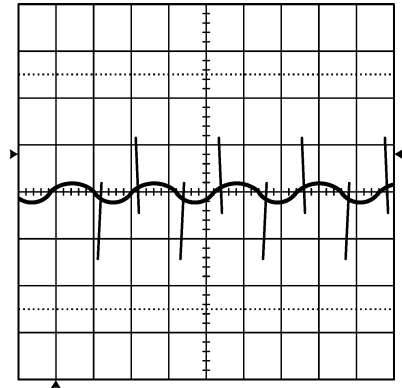

20154605

Conditions: Input Voltage = 48VDC
Output Current = 30A
Bandwidth Limit = 25MHz
Trace 1: Output Ripple Voltage Volts/div = 50mV
Horizontal Resolution = 2μs/div

FIGURE 3.

Figure 3 shows typical output ripple seen directly across the output capacitor, for an input voltage of 48V and a load of 30A. This waveform is typical of most loads and input voltages.

Figure 4 and *Figure 5* show the drain voltage of Q1 with a 25A load. *Figure 4* represents an input voltage of 38V and *Figure 5* represents an input voltage of 78V.

Figure 6 shows the gate voltages of the synchronous rectifiers. The drive from the main power transformer is delayed slightly at turn-on by a resistor interacting with the gate capacitance. This provides improved switching transitions for optimum efficiency. The difference in drive voltage is inherent in the topology and varies with line voltage.

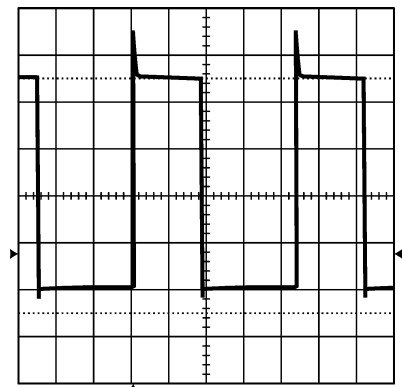

20154606

Conditions: Input Voltage = 38VDC Output Current = 25A
Trace 1: Q1 drain voltage Volts/div = 20V Horizontal Resolution = 1μs/div

FIGURE 4.

Performance Characteristics

(Continued)

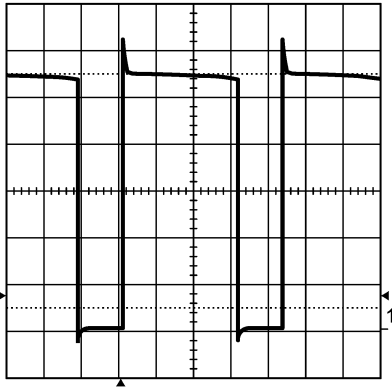

20154607

Conditions: Input Voltage = 78VDC Output Current = 25A
Trace 1: Q1 drain voltage Volts/div = 20V Horizontal Resolution = 1μs/div

FIGURE 5.

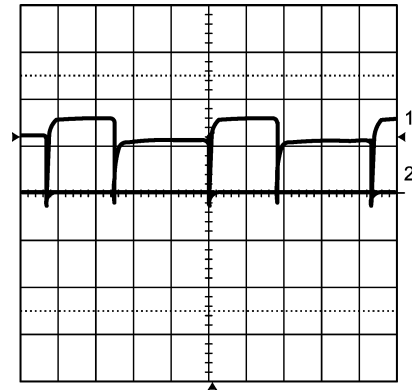

20154608

Conditions: Input Voltage = 48VDC Output Current = 5A
Synchronous rectifier, Q3 gate Volts/div = 5V
Trace 1: Synchronous rectifier, Q3 gate Volts/div = 5V
Trace 2: Synchronous rectifier, Q5 gate Volts/div = 5V
Horizontal Resolution = 1μs/div

FIGURE 6.

Application Circuit

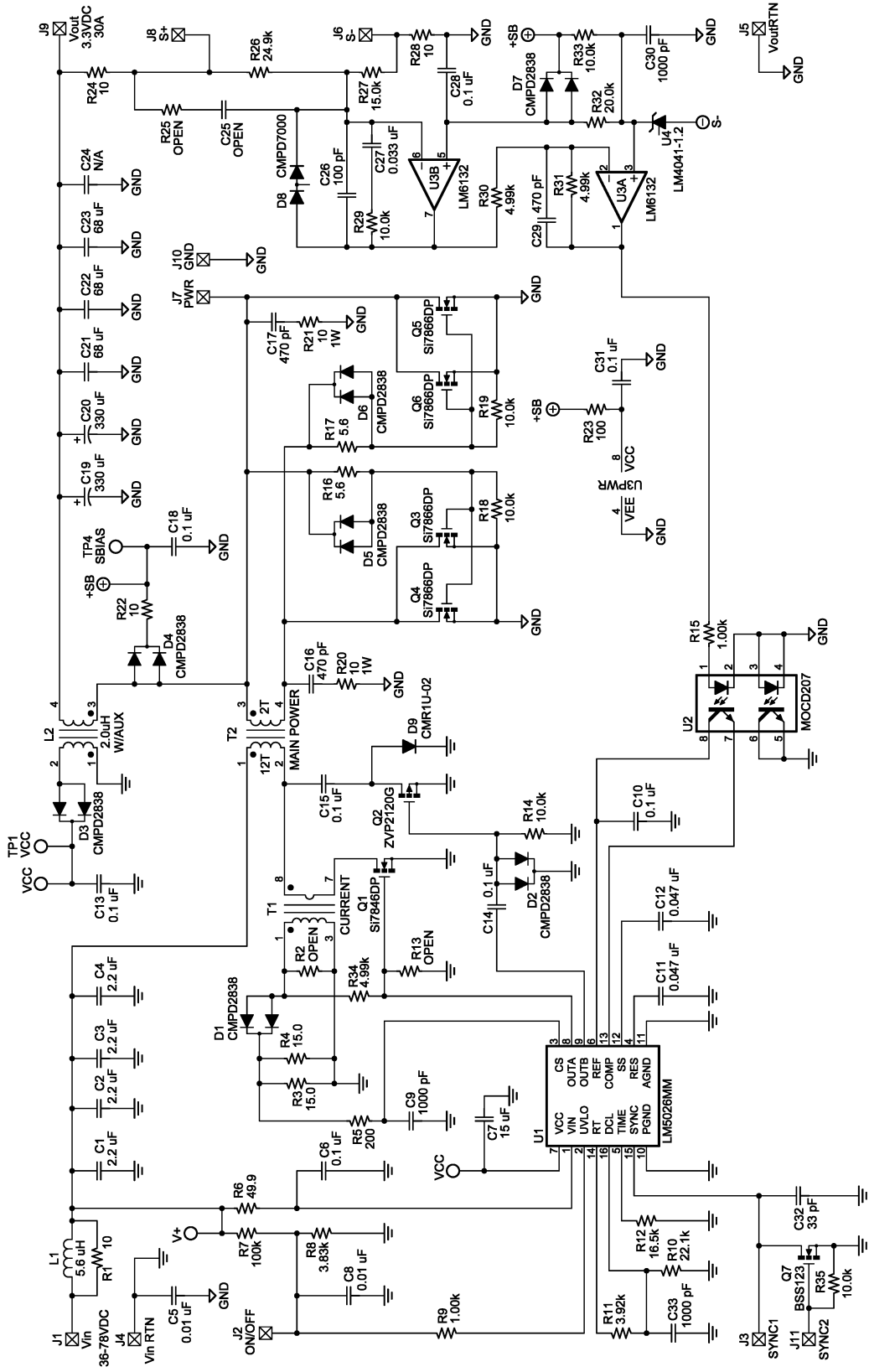

20154603

Application Circuit: Input 36 to 78V, Output 3.3V, 30A

Layout and Bill of Materials

The Bill of Materials is shown below and includes the manufacturer and part number. The layers of the printed circuit board are shown in top down order. View is from the top

down except for the bottom silkscreen which is shown viewed from the bottom. Scale is approximately X1.5. The printed circuit board consists of 4 layers of 3 ounce copper on FR4 material with a total thickness of 0.050 inches.

TABLE 1. Bill of Materials

DESIGNATOR	QTY	PART NUMBER	DESCRIPTION	VALUE
C1-C4	4	C4532X7R2A225M	CAPACITOR, CER, TDK	2.2 μ , 100V
C5	1	C4532X7R3A103K	CAPACITOR, CER, TDK	0.01 μ , 1000V
C6,C15	2	C3216X7R2E104K	CAPACITOR, CER, TDK	0.1 μ , 250V
C7	1	C4532X7R1E156M	CAPACITOR, CER, TDK	15 μ , 25V
C8	1	C2012X7R2A103K	CAPACITOR, CER, TDK	0.01 μ , 100V
C9,C30,C33	3	C2012X7R2A102K	CAPACITOR, CER, TDK	1000p, 100V
C10,C14,C28, C31	4	C2012X7R1H104K	CAPACITOR, CER, TDK	0.1 μ , 50V
C11, C12	2	C2012X7R1H473K	CAPACITOR, CER, TDK	0.047 μ , 50V
C13,C18	2	C1206C104K5RAC	CAPACITOR, CER, KEMET	0.1 μ , 50V
C16, C17, C29	3	C0805C471J5GAC	CAPACITOR, CER, KEMET	470p, 50V
C19,C20	2	T520D337M006AS4350	CAPACITOR,TANT,KEMET	330 μ , 6.3V
C21,C22,C23	3	C4532X7S0G686M	CAPACITOR, CER, TDK	68 μ , 4V
C24, C25		OPEN	NOT USED	
C26	1	C0805C101J5GAC	CAPACITOR, CER, KEMET	100p, 50V
C27	1	C1206C333K5RAC	CAPACITOR, CER, KEMET	0.033 μ , 50V
C32	1	C0805C330J5GAC	CAPACITOR, CER, KEMET	33p, 50V
D1- D7	7	CMPD2838	DIODE, SIGNAL, CENTRAL	
D8	1	CMPD7000	DIODE, SIGNAL, CENTRAL	
D9	1	CMR1U-02	DIODE, 200V, CENTRAL	
L1	1	SLF10145T-5R6M3R2	INPUT CHOKE, TDK	5.6 μ H, 3.5A
L2	1	B0358-C	CHOKE with AUX, COILCRAFT	2 μ H, 33A
Q1	1	SI7846DP	N-FET, SILICONIX	150V, 50m
Q2	1	ZVP2120GTA	P-FET, ZETEX	200V, 20
Q3 - Q6	4	SI7866DP	FET, SILICONIX	20V, 3m
R1, R22, R24, R28	4	CRCW120610R0F	RESISTOR	10 Ω
R2, R13, R25		OPEN	NOT USED	
R3, R4	2	CRCW120615R0F	RESISTOR	15 Ω
R5	1	CRCW12062000F	RESISTOR	200 Ω
R6	1	CRCW120649R9F	RESISTOR	49.9 Ω
R7	1	CRCW12061003F	RESISTOR	100k Ω
R8	1	CRCW12063831F	RESISTOR	3.83k Ω
R9, R15	2	CRCW12061001F	RESISTOR	1k Ω
R10	1	CRCW12062212F	RESISTOR	22.1k Ω
R11	1	CRCW12063921F	RESISTOR	3.92k Ω
R12	1	CRCW12061652F	RESISTOR	16.5k Ω
R14,R18,R19,R29,R33,R35	5	CRCW12061002F	RESISTOR	10k Ω
R16, R17	2	CRCW12065R60F	RESISTOR	5.6 Ω
R20, R21	2	CRCW2512100J	RESISTOR	10 Ω , 1W
R23	1	CRCW12061000F	RESISTOR	100 Ω
R26	1	CRCW12062492F	RESISTOR	24.9k Ω
R27	1	CRCW12061502F	RESISTOR	15k Ω
R30, R31, R34	3	CRCW12064991F	RESISTOR	4.99k Ω
R32	1	CRCW12062002F	RESISTOR	20k Ω
T1	1	P8208T	CURRENT XFR, PULSE ENG	100:01
T2	1	B0357-B	POWER XFR, COILCRAFT	12:02

Layout and Bill of Materials (Continued)**TABLE 1. Bill of Materials** (Continued)

DESIGNATOR	QTY	PART NUMBER	DESCRIPTION	VALUE
U1	1	LM5026MM	CONTROLLER, NATIONAL SEMI	
U2	1	MOCD207M	OPTO-COUPLER, QT OPTO	
U3	1	LM6132AIM	OPAMP, NATIONAL SEMI	
U4	1	LM4041CEM3-1.2	REFERENCE, NATIONAL SEMI	

PCB Layouts

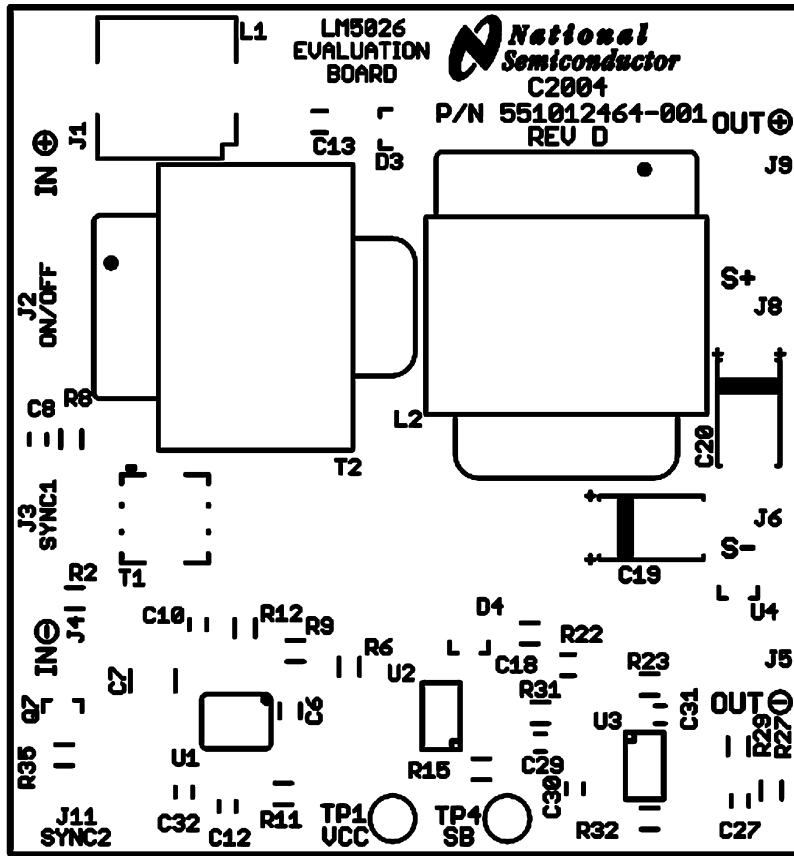

20154609

PCB Layouts (Continued)

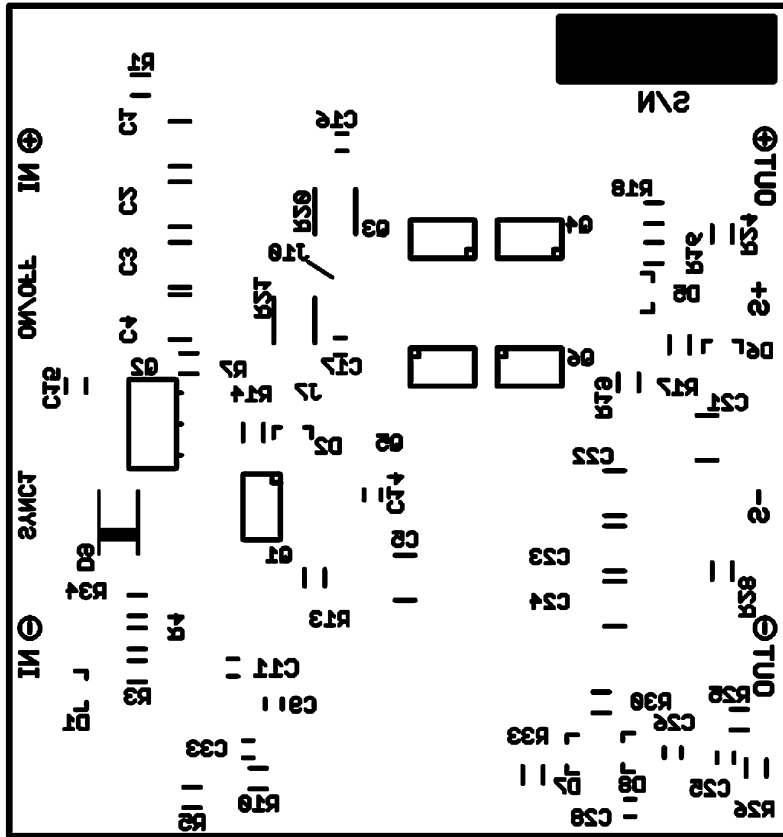

20154610

PCB Layouts (Continued)

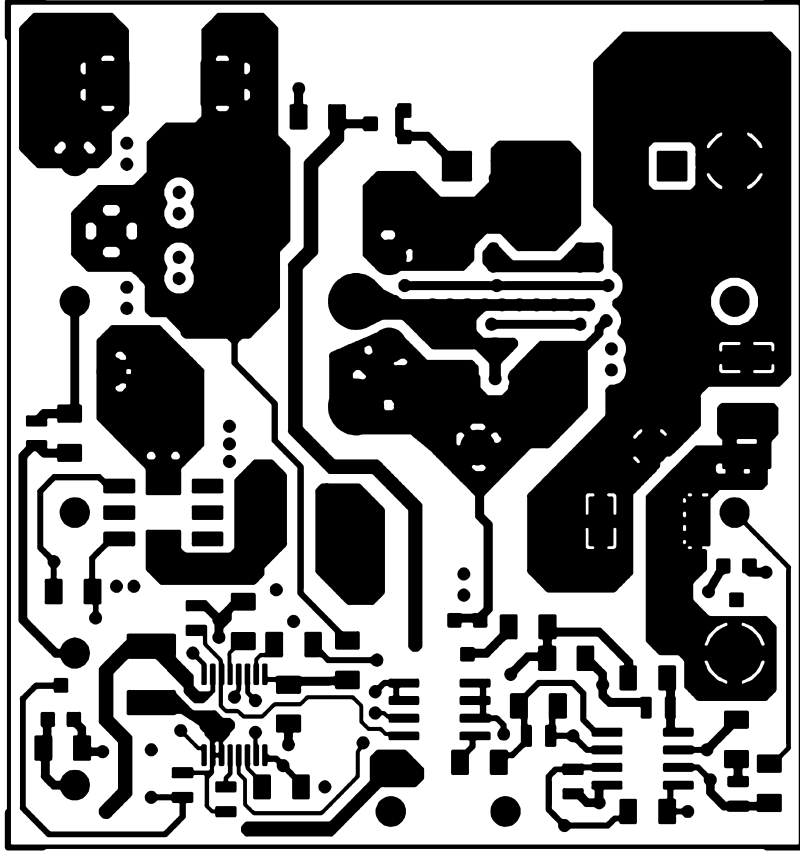

20154611

PCB Layouts (Continued)

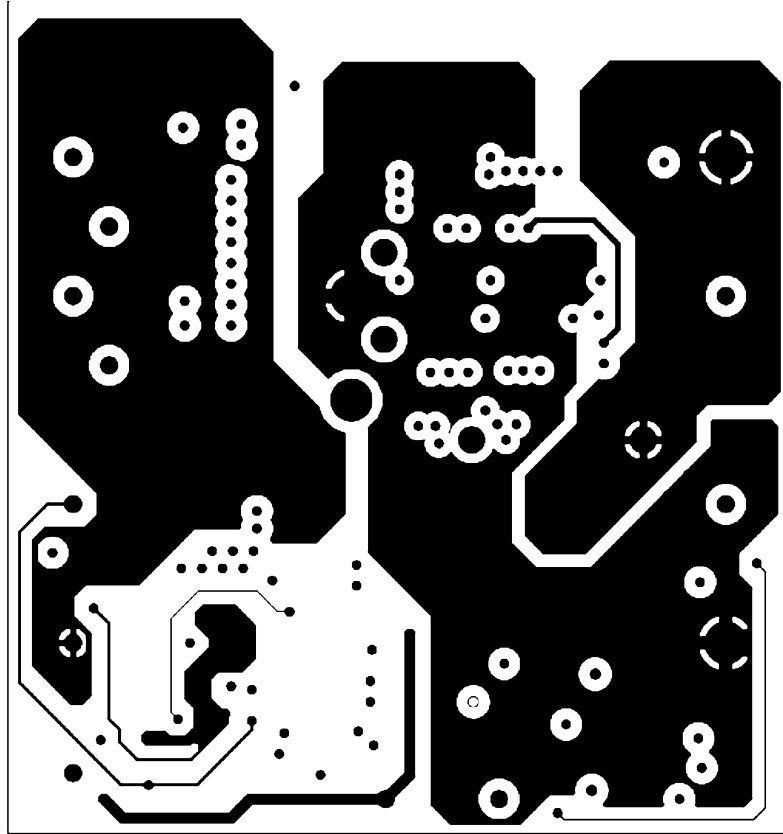

20154612

PCB Layouts (Continued)

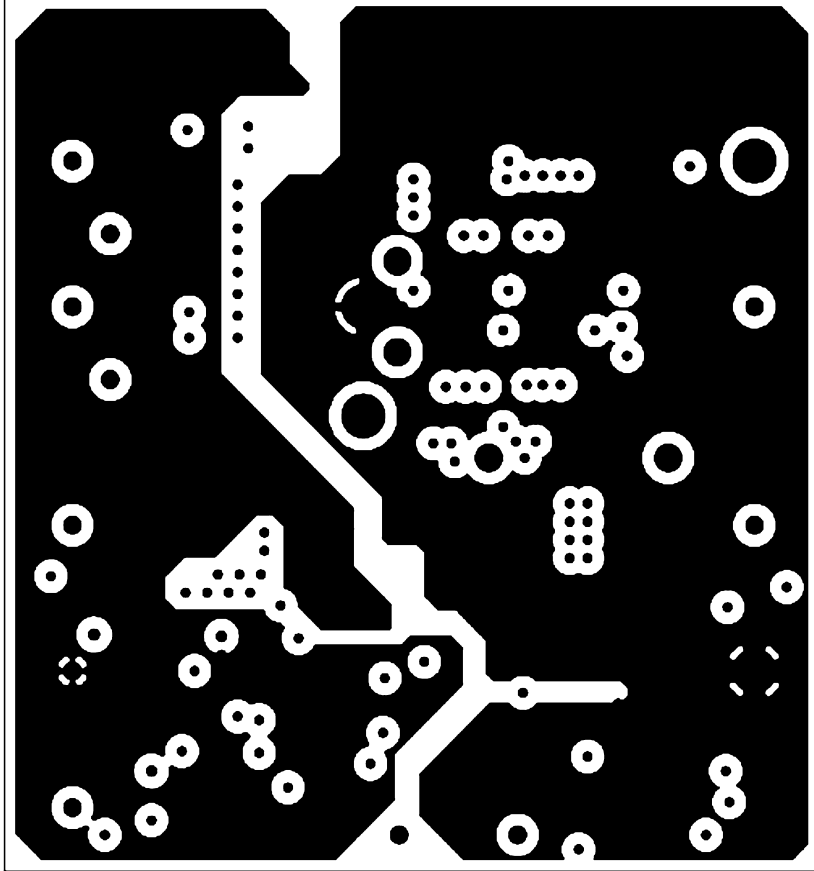

20154613

PCB Layouts (Continued)

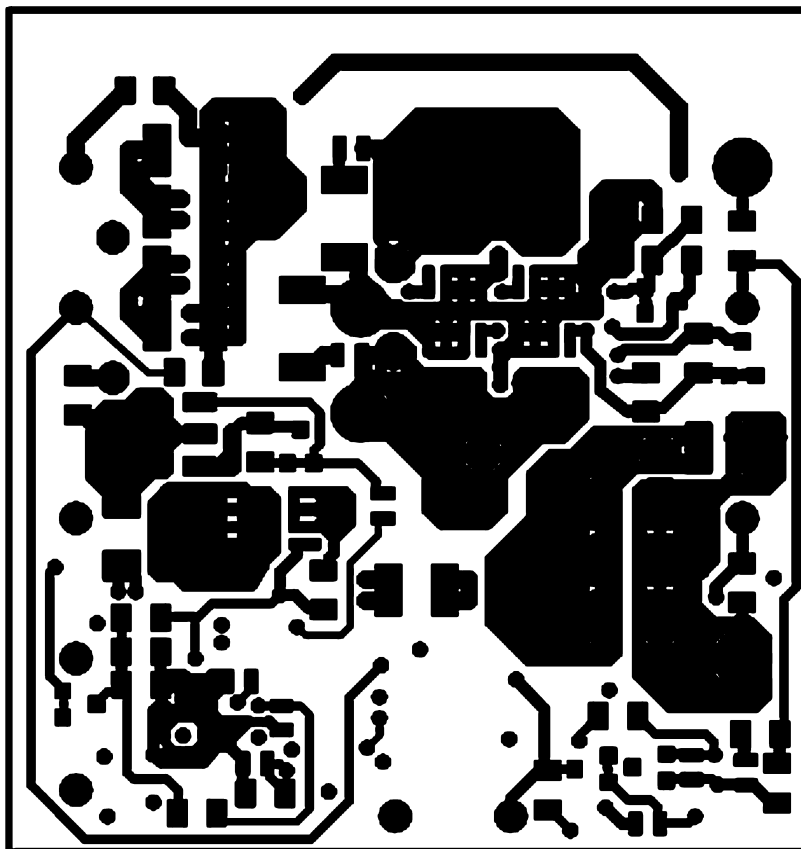

20154614

National does not assume any responsibility for use of any circuitry described, no circuit patent licenses are implied and National reserves the right at any time without notice to change said circuitry and specifications.

For the most current product information visit us at www.national.com.

LIFE SUPPORT POLICY

NATIONAL'S PRODUCTS ARE NOT AUTHORIZED FOR USE AS CRITICAL COMPONENTS IN LIFE SUPPORT DEVICES OR SYSTEMS WITHOUT THE EXPRESS WRITTEN APPROVAL OF THE PRESIDENT AND GENERAL COUNSEL OF NATIONAL SEMICONDUCTOR CORPORATION. As used herein:

1. Life support devices or systems are devices or systems which, (a) are intended for surgical implant into the body, or (b) support or sustain life, and whose failure to perform when properly used in accordance with instructions for use provided in the labeling, can be reasonably expected to result in a significant injury to the user.
2. A critical component is any component of a life support device or system whose failure to perform can be reasonably expected to cause the failure of the life support device or system, or to affect its safety or effectiveness.

BANNED SUBSTANCE COMPLIANCE

National Semiconductor manufactures products and uses packing materials that meet the provisions of the Customer Products Stewardship Specification (CSP-9-111C2) and the Banned Substances and Materials of Interest Specification (CSP-9-111S2) and contain no "Banned Substances" as defined in CSP-9-111S2.

Leadfree products are RoHS compliant.



National Semiconductor
Americas Customer
Support Center
Email: new.feedback@nsc.com
Tel: 1-800-272-9959

National Semiconductor
Europe Customer Support Center
Fax: +49 (0) 180-530 85 86
Email: europe.support@nsc.com
Deutsch Tel: +49 (0) 69 9508 6208
English Tel: +44 (0) 870 24 0 2171
Français Tel: +33 (0) 1 41 91 8790

National Semiconductor
Asia Pacific Customer
Support Center
Email: ap.support@nsc.com

National Semiconductor
Japan Customer Support Center
Fax: 81-3-5639-7507
Email: jpn.feedback@nsc.com
Tel: 81-3-5639-7560

www.national.com